

KBLI12200 12.8V 20Ah



Longer Cycle Life: Offers up to 20 times longer cycle life and five times longer float/calendar life than lead acid battery, helping to minimize replacement cost and reduce total cost of ownership.

Lighter Weight: About 40% of the weight of a comparable lead acid battery. A 'drop in' replacement for lead acid batteries.

Higher Power: Delivers twice power of lead acid battery, even high discharge rate, while maintaining high energy capacity.

Wider Storage Temperature Range: -20 °C-60 °C.

Superior Safety: Prismatic Lithium Iron Phosphate chemistry eliminates the risk of explosion or combustion due to high impact, overcharging or short circuit situation.

Physical Dimension-mm

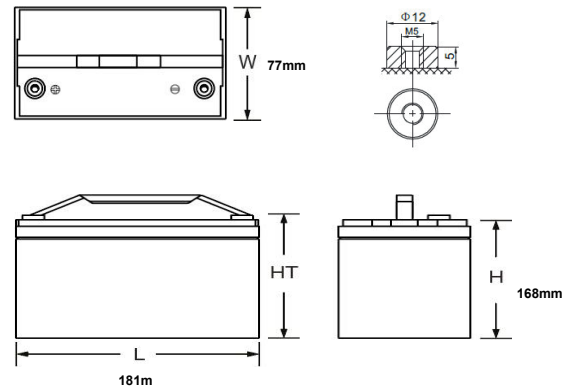

Electrical Performance

Nominal Voltage	12.8 V
Nominal Capacity	20 Ah
Capacity @ 10.8A	300 min
Energy	256 Wh
Resistance	≤50 mΩ @ 50% SOC
Self Discharge	<3% / Month
Cells	26650 Cell 3.2V 4Ah

Charge Performance

Recommended Charge Current	4 A
Maximum Charge Current	10 A
Recommended Charge Voltage	14.6 V
Charge Cut-Off Voltage	<15.2 V (0.5 ~ 1.5 s)
Reconnect Voltage	>14.4 V
Balancing Voltage	<14 V
Maximum Batteries in Series	4
Parallels Support	

Discharge Performance

Continuous Discharge Current	10 A
Maximum continuous Discharge Current	20 A
Peak Discharge Cut-Off Current	40 A (5 ~15 ms)
Recommended Low Voltage Disconnect	10 V
Discharge Cut-Off Voltage	>8.4V (50 ~ 150 ms)
Reconnect Voltage	>10 V
Short Circuit Protection	80 ~ 200 μs

Mechanical Performance

Dimension (L x W x H)	181 x 77 x 168 x 168 mm 7.13 x 3.03 x 6.61 x 6.61"
Approx. Weight	2.5 kg
Terminal Type	M5
Terminal Torque	80 ~ 100 in-lbs (9 ~ 11 N-m)
Case Material	ABS

Temperature Performance

Discharge Temperature	-4 ~ 140 °F (-20 ~ 60 °C)
Charge Temperature	32 ~ 113 °F (0 ~ 45 °C)
Storage Temperature	23 ~ 95 °F (-5 ~ 35 °C)
High Temperature Cut-Off	149 °F (65 °C)
Reconnect Temperature	118 °F (48 °C)

Compliance

Certifications	CE UN38.3 UL1642 & IEC62133
Shipping Classification	UN 3480, CLASS 9

(Note) The Performance may vary depending on application. All specifications are subject to change without prior notice to the user. This data is for evaluation purposes only. No guarantee is intended or implied by this data.

Performance Characteristics

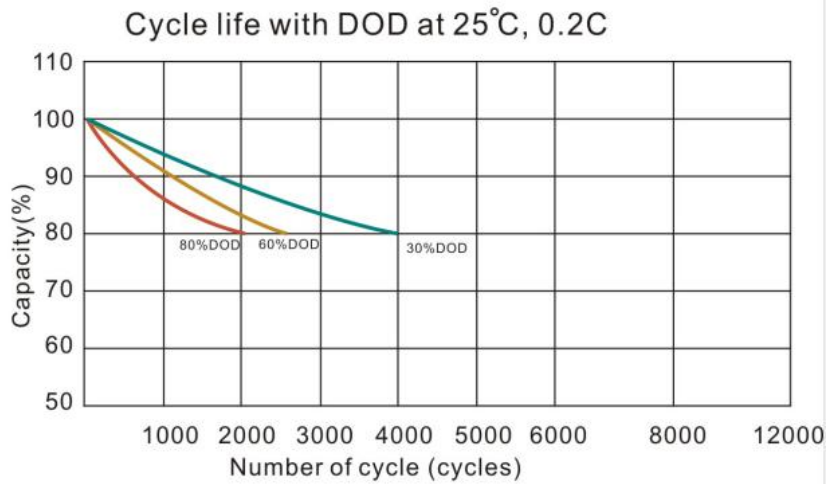
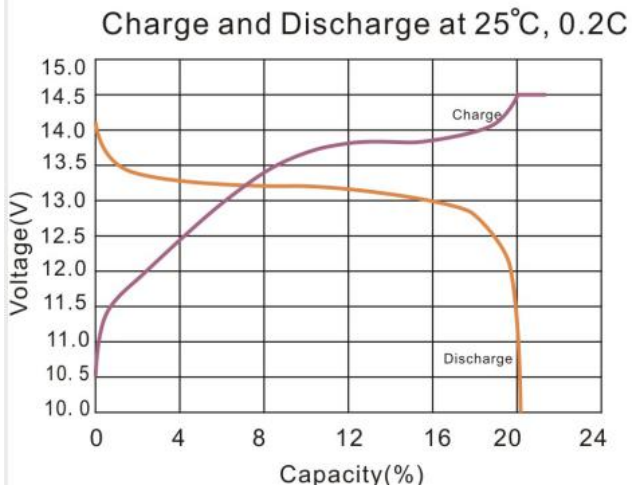
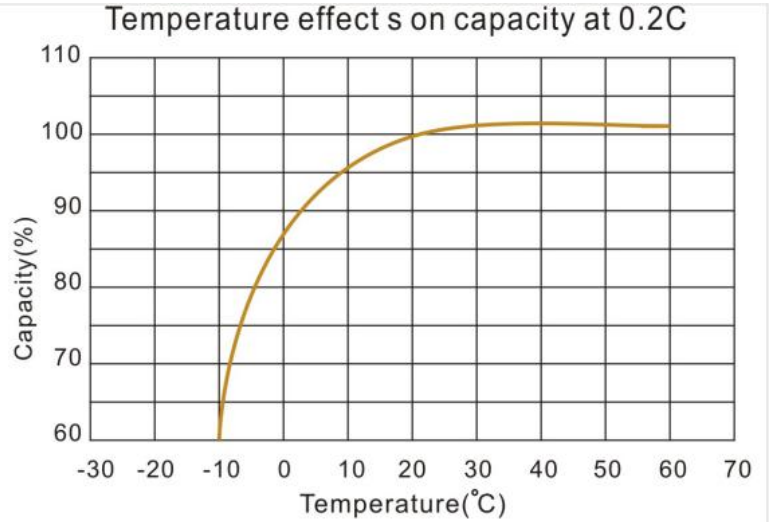
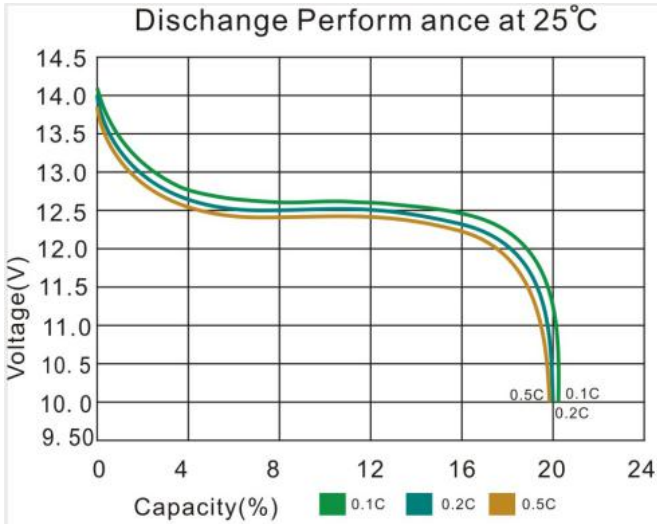

IMPORTANT NOTE: The specifications presented herein are subject to revision without notice.

FEATURES & BENEFITS



High cycle life

>2000 cycles @80% DoD for effectively lower total cost of ownership.



Longer service life

Low maintenance batteries with stable chemistry. Easily monitor state of charge (SoC) of smart models.



Built in circuit protection

Battery Management Systems (BMS) are incorporated against abuse.



Better storage

Up to 6 months thanks to its extremely low self discharge (LSD) rate and no risk of sulphation.



Quickly recharge

Save time and increase productivity with less down time thanks to superior charge/discharge efficiency.



Extreme heat tolerance

Suitable for use in a wider range of applications where ambient temperature is unusually high: up to +60°C.



Lightweight

Lithium batteries provide more Wh/Kg while also being up to 1/3 the weight of its SLA equivalent.

APPLICATIONS

Lithium Iron Phosphate can be used in most applications that use Lead Acid, GEL or AGM type batteries. Suitable applications include:

- Caravan
- Marine
- Wheelchairs and scooters
- Solar / wind energy storage
- Back-up power for small
- UPS Golf trolleys & buggies
- Electric bikes
- Tools

CAUTIONS

- Do NOT short circuit, crush or disassemble.
- Do NOT heat or incinerate.
- Do NOT immerse in any liquid.
- Store at 50% capacity. Recharge every 3 months. The storage area should be clean, cool, dry and ventilated.

(Note) The Performance may vary depending on application. All specifications are subject to change without prior notice to the user. This data is for evaluation purposes only. No guarantee is intended or implied by this data.

