

# KBG12800 12V 65Ah (C<sub>0</sub>)



Gel battery shows some distinctive advantages over flooded battery or AGM battery, such as super thermal stability, high deep discharge capability, good recovery from deep discharge, even if the battery is left discharged for three days, it will recover to 100% of capacity. With the above-mentioned advantages, the gel battery has long service life, specially suitable for motive power applications, such as golf trailer, scrubber, forklift, etc. The deep discharge cycles increased 50% as compared with the AGM battery.



## Performance Characteristics

Nominal Voltage	12V	
Design Life	12 years	
Dimensions	Length (mm / inch)	350±2 / 1.8
	Width (mm / inch)	166±2 / 6.5
	Height (mm / inch)	175±2 / 6.89
	Total Height (mm / inch)	175±2 / 6.89
Approx. Weight	(Kg / lbs)	2 / 4
	Terminal	M
Container Material	ABS	
Rated Capacity	65.0Ah / 6.50A	(10hr, 1.80V / cell, 25°C / 77°F)
	58.0Ah / 11.6A	(5hr, 1.75V / cell, 25°C / 77°F)
	42.9Ah / 42.9A	(1hr, 1.60V / cell, 25°C / 77°F)
Max. Discharge Current	0A (5s)	
Internal Resistance	Approx. 2mΩ	
Operating Temp. Range	Discharge : -0 ~ °C (-4 ~ 1 °F)	
	Charge : -20 ~ 0°C (-4 ~ 1°F)	
	Storage : - ~ 50°C (- ~ 122°F)	
Cycle Use	Initial charging current less than 16.3A	
	Voltage 14.4V ~ 15.0V at 25°C (77°F)	
	Temp. Coefficient: -30mV/°C	
Standby Use	Initial charging current less than 16.3A	
	Voltage 13.5V ~ 13.8V at 25°C (77°F)	
	Temp. Coefficient: -18mV/°C	
Capacity affected by Temperature	40°C (104°F)	103%
	25°C (77°F)	100%
	0°C (32°F)	86%
Self Discharge	Fully charged Kaise Gel Series batteries may be stored for up to 6 months at 25°C (77°F) and then a freshening charge is required. For higher temperatures the time interval will be shorter.	

## Discharge Constant Current (Amperes) at 77°F (25°C)

Volts/cell	15min	30min	1h	2h	3h	5h	10h	20h
1.80V							6.50	3.47
1.75V							6.53	3.49
1.70V							6.60	3.50
1.6V							6.66	3.52
1.60V							6.73	3.54

## Dimensions and Terminal (Unit: mm (inches))

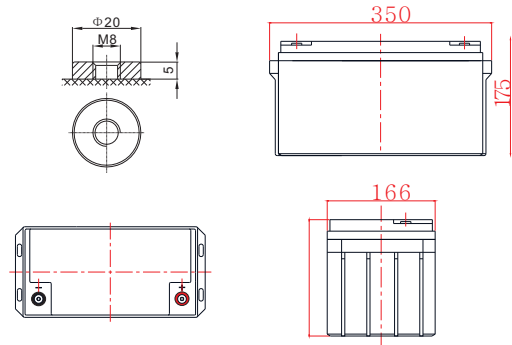

## Applications

- Wind and solar energy systems
- Cable TV systems
- Telecommunications
- Electric wheel chairs
- Military equipment
- Emergency lighting
- Power plants
- Medical equipment
- Golf carts

## Certifications

ISO 9001 / ISO 14001



## Discharge End Voltage vs. Discharge Current

Final discharge voltage V/CELL	1.8	1.75	1.7	1.6
Discharge current (A)	I ≤ 0.1CA	0.25CA ≥ I > 0.1CA	0.55CA ≥ I > 0.25CA	I > 0.55CA

## Discharge Constant Power (Watts per cell) at 77°F (25°C)

Volts/cell	15min	30min	1h	3h	5h	10h	20h
1.80V							
1.75V							
1.70V							
1.6V							
1.60V							

(Note) The above characteristics data are average values obtained within three charge/discharge cycles not the minimum values.

## Charging Characteristics

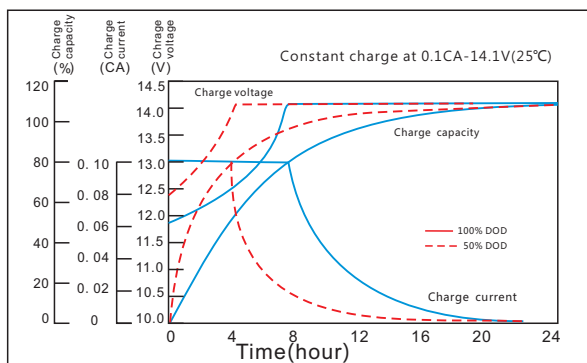

## Discharge Characteristics

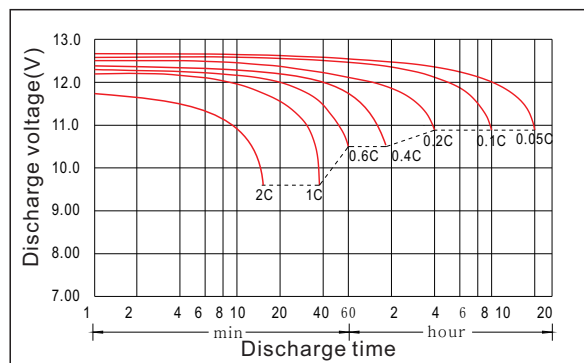

## The effect of discharge depth on cycle life

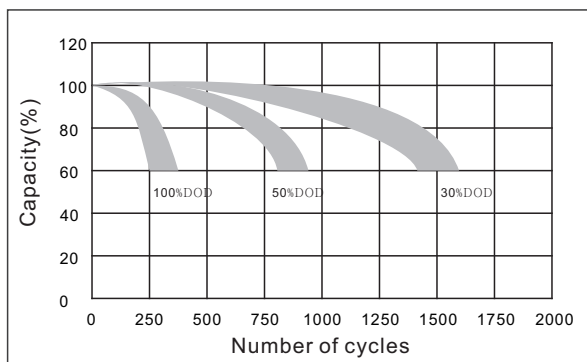

## The effect of temperature on capacity

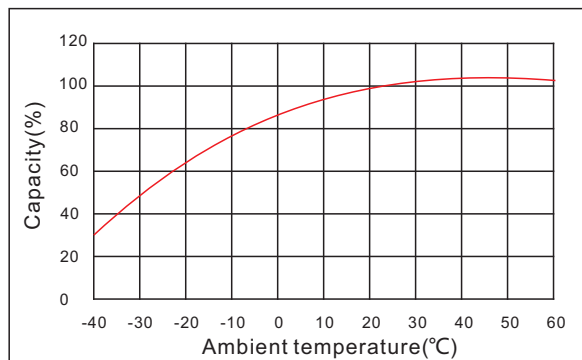

## Curves of self-discharge

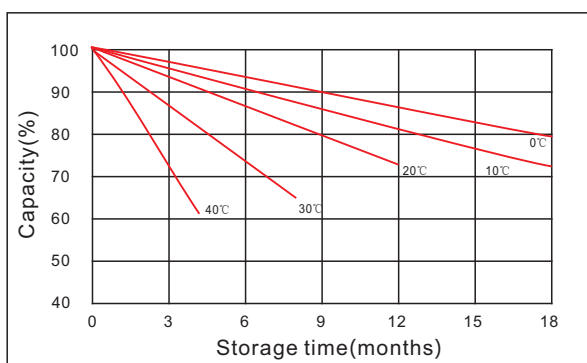

## Curves of open circuit voltage vs. capacity

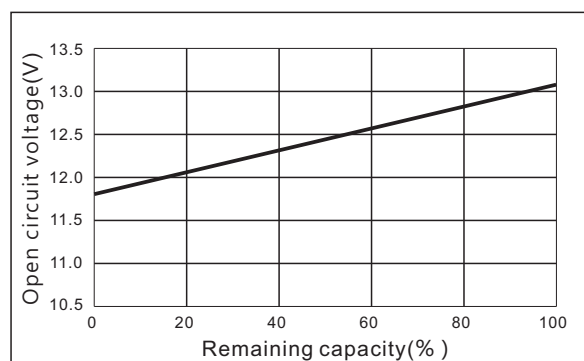

IMPORTANT NOTE: The specifications presented herein are subject to revision without notice.

