

KBC12450 12V 45Ah



The Kaise cyclic batteries were developed for deep discharges with very heavy non-porous battery plates to withstand major discharging and charging cycles (deep cycle). These batteries use different chemistry combinations for the plates with active paste material and a slightly stronger than normal electrolyte, which allows for a much longer life in deep cycle applications.



Performance Characteristics

Nominal Voltage	12V	
Dimensions	Length (mm / inch)	197 / 7.76
	Width (mm / inch)	165 / 6.50
	Height (mm / inch)	172 / 6.78
	Total Height (mm / inch)	172 / 6.78
Approx Weight	(Kg / lbs) 15.0 / 33.1	
Design Life	12 years	
Terminal	M6	
Container Material	ABS	
Rated Capacity	45.0Ah / 4.50A	(10hr, 1.80V / cell, 25°C / 77°F)
	41.0Ah / 8.20A	(5hr, 1.75V / cell, 25°C / 77°F)
	29.9Ah / 29.9A	(1hr, 1.70V / cell, 25°C / 77°F)
Max. Discharge Current	540A (5s)	
Internal Resistance	Approx 11.8 mΩ	
Operating Temp. Range	Discharge : -20 ~ 50°C (-4 ~ 122°F)	
	Charge : -20 ~ 50°C (-4 ~ 122°F)	
	Storage : -20 ~ 50°C (-4 ~ 122°F)	
Cycle Use	Initial Charging Current less than 11.3A	
	Voltage: 14.4V- 15.0V at 25°C (77°F)	
	Temp. Coefficient: -30mV/°C	
Standby Use	Initial Charging Current less than 11.3A	
	Voltage: 13.5V ~ 13.8V at 25°C (77°F)	
	Temp. Coefficient: -18mV/°C	
Capacity affected by Temperature	40°C (104°F)	103%
	25°C (77°F)	100%
	0°C (32°F)	86%
Self Discharge	Fully charged Kaise Deep Cycle Series batteries may be stored for up to 6 months at 25°C (77°F) and then a freshening charge is required. For higher temperatures the time interval will be shorter.	

Discharge Constant Current (Amperes) at 25°C (77°F)

Volts/cell	5min	15min	30min	1h	3h	5h	10h	20h
1.80V	122	72.9	47.5	28.7	12.1	7.98	4.50	2.41
1.75V	136	78.2	49.6	29.5	12.2	8.20	4.55	2.42
1.70V	148	80.8	50.1	29.9	12.3	8.29	4.59	2.43
1.65V	154	82.6	50.9	30.1	12.5	8.38	4.64	2.44
1.60V	159	85.2	51.8	30.3	12.6	8.47	4.68	2.46

Dimensions and Terminal (Unit: mm (inches))

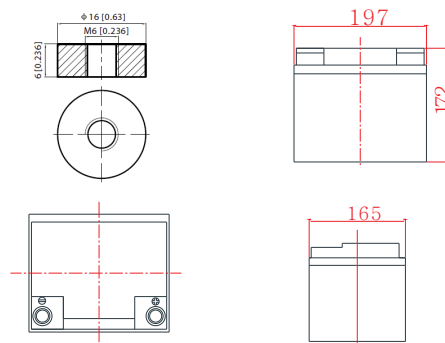

Applications

- Solar power systems
- Electric wheel chairs
- Golf carts
- Maritime equipment
- Power plants
- Railway systems
- Telecommunications systems
- Cable TV systems
- Emergency power systems

Certifications

ISO 9001 / ISO 14001



Discharge Current vs. Discharge Voltage

Final discharge voltage V/CELL	1.8	1.75	1.7	1.6
Discharge current (A)	$I \leq 0.1CA$	$0.25CA \geq I > 0.1CA$	$0.55CA \geq I > 0.25CA$	$I > 0.55CA$

Discharge Constant Power (Watts per cell) at 25°C (77°F)

Volts/cell	5min	15min	30min	1h	2h	3h	5h
1.80V	218	137	90.2	55.5	32.4	23.3	15.6
1.75V	237	145	92.4	56.0	32.5	23.4	15.7
1.70V	254	146	92.9	56.4	32.6	23.5	15.8
1.65V	256	147	92.9	56.8	32.8	23.7	16.0
1.60V	266	150	93.8	57.3	32.9	24.0	16.1

(Note) The above characteristics data are average values obtained within three charge/discharge cycles not the minimum values.

Charging Characteristics (standby use)

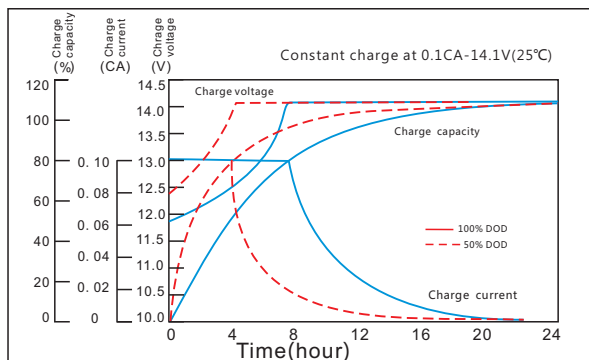

Self Discharge Characteristics

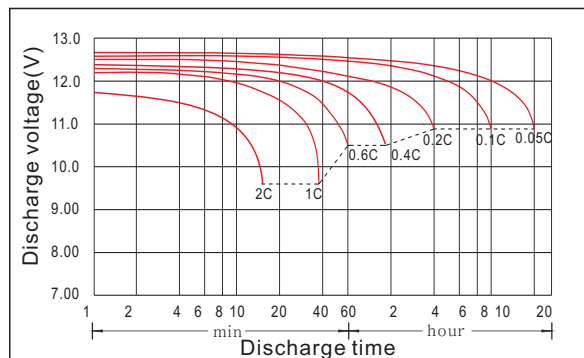

Temperature Effects in Relation to Battery Capacity

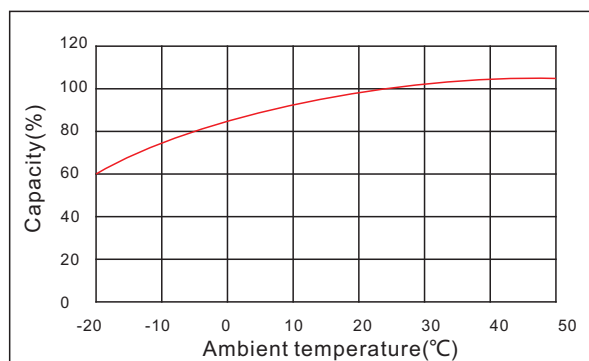

Temperature Effects on Float Life

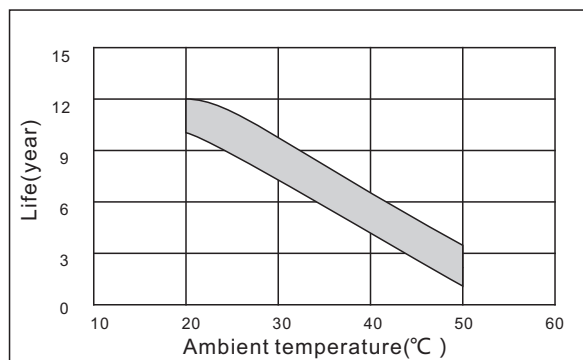

Cycle Life in Relation to Depth of Discharge

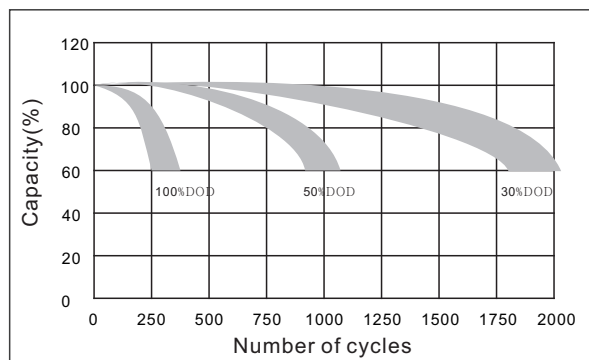

Curves of self-discharge

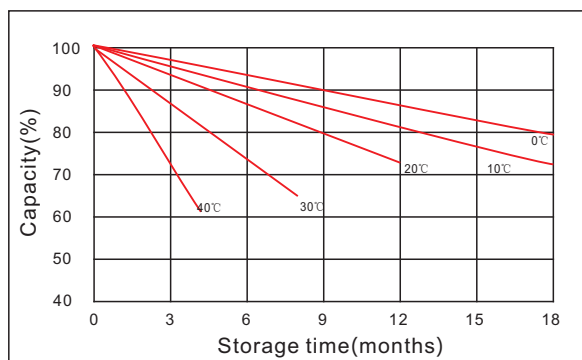

IMPORTANT NOTE: The specifications presented herein are subject to revision without notice.

