

KBC12750 12V 75Ah



The Kaise cyclic batteries were developed for deep discharges with very heavy non-porous battery plates to withstand major discharging and charging cycles (deep cycle). These batteries use different chemistry combinations for the plates with active paste material and a slightly stronger than normal electrolyte, which allows for a much longer life in deep cycle applications.



Performance Characteristics

Nominal Voltage	12V	
Dimensions	Length (mm / inch)	258 / 10.16
	Width (mm / inch)	168 / 6.61
	Height (mm / inch)	212 / 8.35
	Total Height (mm / inch)	215 / 8.46
Approx Weight	(Kg / lbs) 22.5 / 49.7	
Design Life	12 years	
Terminal	M6	
Container Material	ABS	
Rated Capacity	74.8Ah / 3.74A	(20hr, 1.80V / cell, 25°C / 77°F)
	62.5Ah / 12.5A	(5hr, 1.75V / cell, 25°C / 77°F)
	45.6Ah / 45.6A	(1hr, 1.70V / cell, 25°C / 77°F)
Max. Discharge Current	840A (5s)	
Internal Resistance	Approx 8.0mΩ	
Operating Temp. Range	Discharge : -40 ~ 60°C (-40 ~ 140°F)	
	Charge : -20 ~ 50°C (-4 ~ 122°F)	
	Storage : -20 ~ 50°C (-4 ~ 122°F)	
Cycle Use	Initial Charging Current less than 17.5A	
	Voltage: 14.4V- 15.0V at 25°C (77°F)	
	Temp. Coefficient: -30mV/°C	
Standby Use	Initial Charging Current less than 17.5A	
	Voltage: 13.5V ~ 13.8V at 25°C (77°F)	
	Temp. Coefficient: -18mV/°C	
Capacity affected by Temperature	40°C (104°F)	103%
	25°C (77°F)	100%
	0°C (32°F)	86%
Self Discharge	Fully charged Kaise Deep Cycle Series batteries may be stored for up to 6 months at 25°C (77°F) and then a freshening charge is required. For higher temperatures the time interval will be shorter.	

Discharge Constant Current (Amperes) at 25°C (77°F)

Volts/cell	15min	30min	1h	2h	3h	5h	10h	20h
1.80V	110	71.6	43.8	25.3	18.4	12.2	7.00	3.74
1.75V	118	74.9	44.9	25.7	18.6	12.5	7.03	3.76
1.70V	122	75.5	45.6	26.2	18.8	12.6	7.10	3.77
1.65V	125	76.9	45.9	26.4	19.0	12.8	7.17	3.79
1.60V	129	78.2	46.2	26.5	19.2	12.9	7.24	3.81

Dimensions and Terminal (Unit: mm (inches))

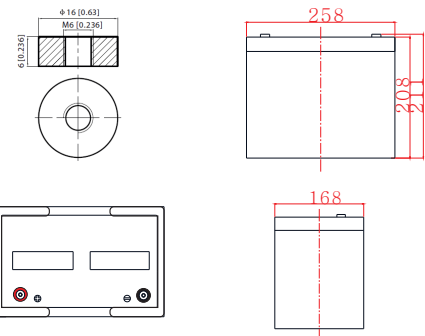

Applications

- Solar power systems
- Electric wheel chairs
- Golf carts
- Maritime equipment
- Power plants
- Railway systems
- Telecommunications systems
- Cable TV systems
- Emergency power systems

Certifications

ISO 9001 / ISO 14001



Discharge Current vs. Discharge Voltage

Final discharge voltage V/CELL	1.8	1.75	1.7	1.6
Discharge current (A)	$I \leq 0.1CA$	$0.25CA \geq I > 0.1CA$	$0.55CA \geq I > 0.25CA$	$I > 0.55CA$

Discharge Constant Power (Watts per cell) at 25°C (77°F)

Volts/cell	15min	30min	1h	2h	3h	5h	10h
1.80V	207	136	84.6	49.3	35.6	23.7	13.4
1.75V	218	139	85.3	49.5	35.7	24.0	13.5
1.70V	220	140	86.0	49.7	35.9	24.1	13.7
1.65V	222	140	86.7	50.0	36.1	24.3	13.8
1.60V	226	141	87.3	50.1	36.6	24.5	13.9

(Note) The above characteristics data are average values obtained within three charge/discharge cycles not the minimum values.

Charging Characteristics (standby use)

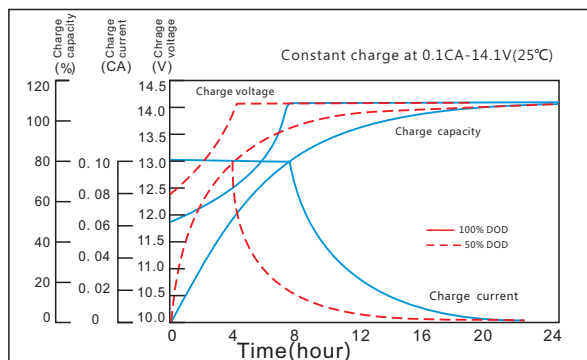

Discharge Characteristics

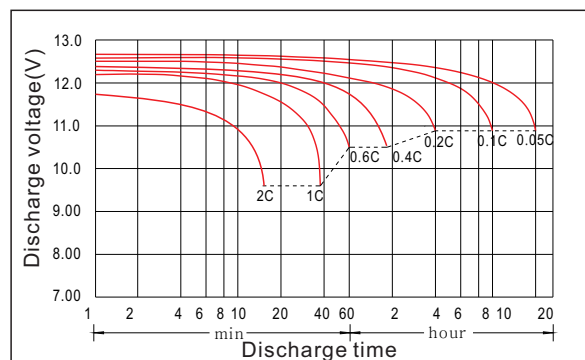

Temperature Effects in Relation to Battery Capacity

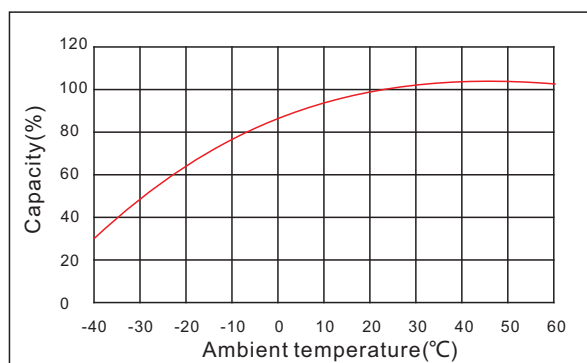

Cycle Life in Relation to Depth of Discharge

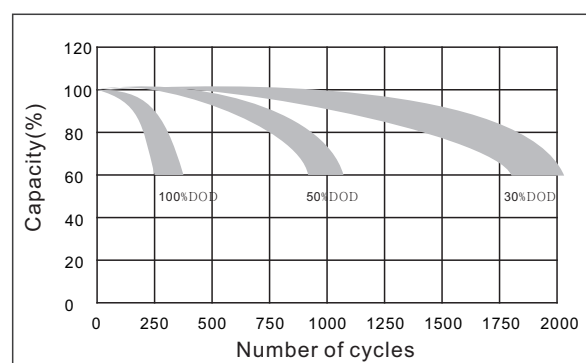

Curves of Self-Discharge

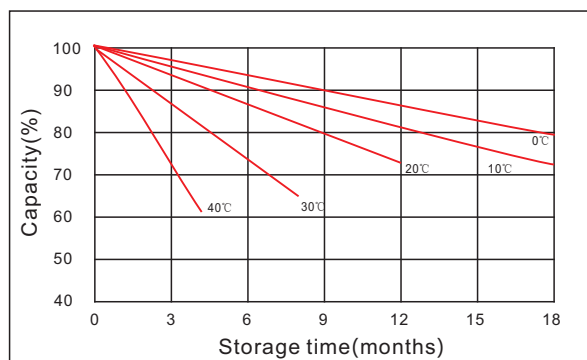

Curves of Open Circuit Voltage vs. Capacity

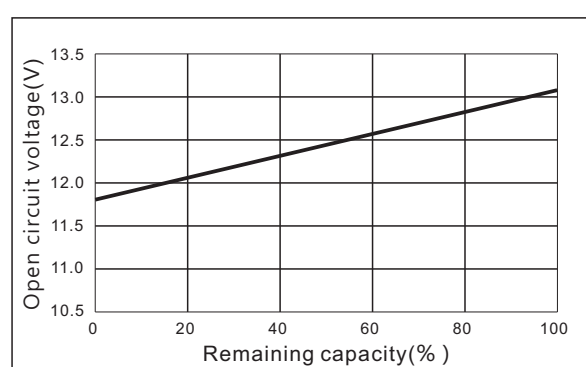

IMPORTANT NOTE: The specifications presented herein are subject to revision without notice.

2024/NK

